

AM26C31 QUADRUPLE DIFFERENTIAL LINE DRIVER

SLLS103J – DECEMBER 1990 – REVISED NOVEMBER 2003

- Meets or Exceeds the Requirements of TIA/EIA-422-B and ITU Recommendation V.11
- Low Power, $I_{CC} = 100 \mu\text{A Typ}$
- Operates From a Single 5-V Supply
- High Speed, $t_{pLH} = t_{pHL} = 7 \text{ ns Typ}$
- Low Pulse Distortion, $t_{sk(p)} = 0.5 \text{ ns Typ}$
- High Output Impedance in Power-Off Conditions
- Improved Replacement for AM26LS31
- Available in Q-Temp Automotive
 - High-Reliability Automotive Applications
 - Configuration Control/Print Support
 - Qualification to Automotive Standards

description/ordering information

The AM26C31 is a differential line driver with complementary outputs, designed to meet the requirements of TIA/EIA-422-B and ITU (formerly CCITT). The 3-state outputs have high-current capability for driving balanced lines, such as twisted-pair or parallel-wire transmission lines, and they provide the high-impedance state in the power-off condition. The enable functions are common to all four drivers and offer the choice of an active-high (G) or active-low (\bar{G}) enable input. BiCMOS circuitry reduces power consumption without sacrificing speed.

The AM26C31C is characterized for operation from 0°C to 70°C, the AM26C31I is characterized for operation from –40°C to 85°C, the AM26C31Q is characterized for operation over the automotive temperature range of –40°C to 125°C, and the AM26C31M is characterized for operation over the full military temperature range of –55°C to 125°C.

AM26C31M . . . J OR W PACKAGE
AM26C31Q . . . D PACKAGE
AM26C31C/I . . . D, DB, N, OR NS PACKAGE
(TOP VIEW)

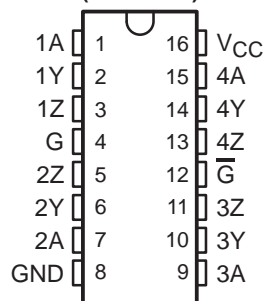

AM26C31M . . . FK PACKAGE
(TOP VIEW)

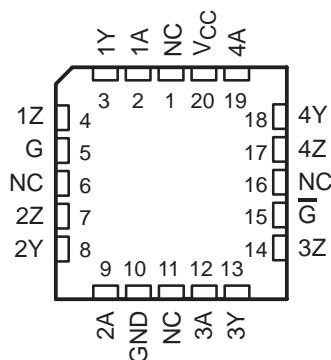

NC – No internal connection



Please be aware that an important notice concerning availability, standard warranty, and use in critical applications of Texas Instruments semiconductor products and disclaimers thereto appears at the end of this data sheet.

PRODUCTION DATA information is current as of publication date. Products conform to specifications per the terms of Texas Instruments standard warranty. Production processing does not necessarily include testing of all parameters.

 **TEXAS
INSTRUMENTS**

POST OFFICE BOX 655303 • DALLAS, TEXAS 75265

Copyright © 2003, Texas Instruments Incorporated
On products compliant to MIL-PRF-38535, all parameters are tested unless otherwise noted. On all other products, production processing does not necessarily include testing of all parameters.

AM26C31

QUADRUPLE DIFFERENTIAL LINE DRIVER

SLLS103J – DECEMBER 1990 – REVISED NOVEMBER 2003

description/ordering information (continued)

ORDERING INFORMATION

TA	PACKAGE†		ORDERABLE PART NUMBER	TOP-SIDE MARKING
0°C to 70°C	PDIP (N)	Tube of 25	AM26C31CN	AM26C31CN
	SOIC (D)	Tube of 40	AM26C31CD	AM26C31C
		Reel of 2500	AM26C31CDR	
	SOP (NS)	Reel of 2000	AM26C31CNSR	26C31
	SSOP (DB)	Reel of 2000	AM26C31CDBR	26C31
-40°C to 85°C	PDIP (N)	Tube of 25	AM26C31IN	AM26C31IN
	SOIC (D)	Tube of 40	AM26C31ID	AM26C31C
		Reel of 2500	AM26C31IDR	
	SOP (NS)	Reel of 2000	AM26C31INSR	26C31
	SSOP (DB)	Reel of 2000	AM26C31IDBR	26C31
-40°C to 125°C	SOIC (D)	Tube of 40	AM26C31QD	AM26C31QD
		Reel of 2500	AM26C31QDR	
-55°C to 125°C	CDIP (J)	Tube of 25	AM26C31MJ	AM26C31MJ
	CFP (W)	Tube of 150	AM26C31MW	AM26C31MW
	LCCC (FK)	Tube of 55	AM26C31MFK	AM26C31MFK

† Package drawings, standard packing quantities, thermal data, symbolization, and PCB design guidelines are available at www.ti.com/sc/package.

FUNCTION TABLE (each driver)

INPUT A	ENABLES		OUTPUTS	
	G	\bar{G}	Y	Z
H	H	X	H	L
L	H	X	L	H
H	X	L	H	L
L	X	L	L	H
X	L	H	Z	Z

H = High level, L = Low level, X = Irrelevant,
Z = High impedance (off)

AM26C31 QUADRUPLE DIFFERENTIAL LINE DRIVER

SLLS103J – DECEMBER 1990 – REVISED NOVEMBER 2003

logic diagram (positive logic)

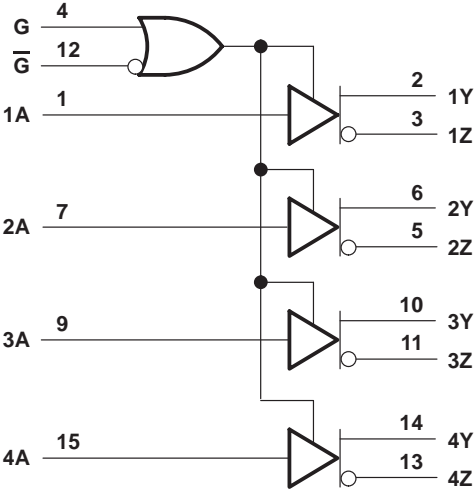

schematics of inputs and outputs

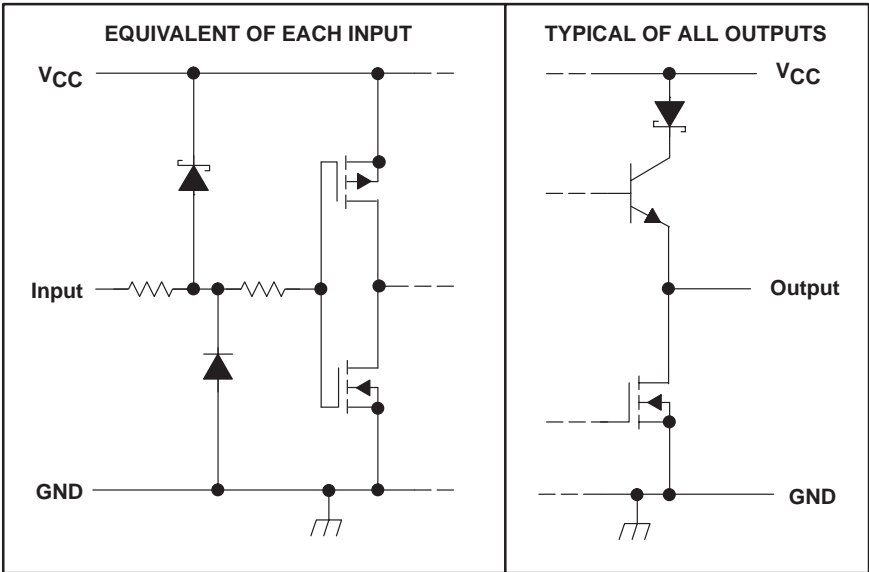

AM26C31

QUADRUPLE DIFFERENTIAL LINE DRIVER

SLLS103J – DECEMBER 1990 – REVISED NOVEMBER 2003

absolute maximum ratings over operating free-air temperature range (unless otherwise noted)†

Supply voltage range, V_{CC} (see Note 1)	–0.5 V to 7 V
Input voltage range, V_I	–0.5 V to $V_{CC} + 0.5$ V
Differential input voltage range, V_{ID}	–14 V to 14 V
Output voltage range, V_O	–0.5 V to 7 V
Input or output clamp current, I_{IK} or I_{OK}	±20 mA
Output current, I_O	±150 mA
V_{CC} current	200 mA
GND current	–200 mA
Package thermal impedance, θ_{JA} (see Notes 2 and 3):	
D package	73°C/W
DB package	82°C/W
N package	67°C/W
NS package	64°C/W
Operating virtual junction temperature, T_J	150°C
Storage temperature range, T_{stg}	–65°C to 150°C

† Stresses beyond those listed under “absolute maximum ratings” may cause permanent damage to the device. These are stress ratings only, and functional operation of the device at these or any other conditions beyond those indicated under “recommended operating conditions” is not implied. Exposure to absolute-maximum-rated conditions for extended periods may affect device reliability.

- NOTES: 1. All voltage values, except differential output voltage (V_{OD}), are with respect to the network ground terminal.
 2. Maximum power dissipation is a function of $T_J(\max)$, θ_{JA} , and T_A . The maximum allowable power dissipation at any allowable ambient temperature is $P_D = (T_J(\max) - T_A)/\theta_{JA}$. Operating at the absolute maximum T_J of 150°C can affect reliability.
 3. The package thermal impedance is calculated in accordance with JESD 51-7.

recommended operating conditions

		MIN	NOM	MAX	UNIT
V_{CC}	Supply voltage	4.5	5	5.5	V
V_{ID}	Differential input voltage	±7			V
V_{IH}	High-level input voltage	2			V
V_{IL}	Low-level input voltage			0.8	V
I_{OH}	High-level output current			–20	mA
I_{OL}	Low-level output current			20	mA
T_A	Operating free-air temperature	AM26C31C	0	70	°C
		AM26C31I	–40	85	
		AM26C31Q	–40	125	
		AM26C31M	–55	125	



AM26C31 QUADRUPLE DIFFERENTIAL LINE DRIVER

SLLS103J – DECEMBER 1990 – REVISED NOVEMBER 2003

electrical characteristics over recommended ranges of supply voltage and operating free-air temperature (unless otherwise noted)

PARAMETER	TEST CONDITIONS	AM26C31C AM26C31I			UNIT
		MIN	TYP†	MAX	
V _{OH} High-level output voltage	I _O = -20 mA	2.4	3.4		V
V _{OL} Low-level output voltage	I _O = 20 mA		0.2	0.4	V
V _{OD} Differential output voltage magnitude	R _L = 100 Ω, See Figure 1	2	3.1		V
Δ V _{OD} Change in magnitude of differential output voltage‡	R _L = 100 Ω, See Figure 1			±0.4	V
V _{OC} Common-mode output voltage	R _L = 100 Ω, See Figure 1			3	V
Δ V _{OC} Change in magnitude of common-mode output voltage‡	R _L = 100 Ω, See Figure 1			±0.4	V
I _I Input current	V _I = V _{CC} or GND			±1	μA
I _{O(off)} Driver output current with power off	V _{CC} = 0 V _O = 6 V V _O = -0.25 V			100 -100	μA
I _{OS} Driver output short-circuit current	V _O = 0	-30		-150	mA
I _{OZ} High-impedance off-state output current	V _O = 2.5 V V _O = 0.5 V			20 -20	μA
I _{CC} Quiescent supply current	I _O = 0 V _I = 0 V or 5 V V _I = 2.4 V or 0.5 V, See Note 4		1.5	3	mA
C _i Input capacitance			6		pF

† All typical values are at V_{CC} = 5 V and T_A = 25°C.

‡ Δ|V_{OD}| and Δ|V_{OC}| are the changes in magnitude of V_{OD} and V_{OC}, respectively, that occur when the input is changed from a high level to a low level.

NOTE 4: This parameter is measured per input. All other inputs are at 0 or 5 V.

switching characteristics over recommended ranges of supply voltage and operating free-air temperature (unless otherwise noted)

PARAMETER	TEST CONDITIONS	AM26C31C AM26C31I			UNIT
		MIN	TYP†	MAX	
t _{PLH} Propagation delay time, low- to high-level output	S1 is open, See Figure 2	3	7	12	ns
t _{PHL} Propagation delay time, high- to low-level output	S1 is open, See Figure 2	3	7	12	ns
t _{sk(p)} Pulse skew time (t _{PLH} - t _{PHL})	S1 is open, See Figure 2		0.5	4	ns
t _{r(OD)} , t _{f(OD)} Differential output rise and fall times	S1 is open, See Figure 3		5	10	ns
t _{PZH} Output enable time to high level	S1 is closed, See Figure 4		10	19	ns
t _{PZL} Output enable time to low level	S1 is closed, See Figure 4		10	19	ns
t _{PHZ} Output disable time from high level	S1 is closed, See Figure 4		7	16	ns
t _{PLZ} Output disable time from low level	S1 is closed, See Figure 4		7	16	ns
C _{pd} Power dissipation capacitance (each driver) (see Note 5)	S1 is open, See Figure 2		170		pF

† All typical values are at V_{CC} = 5 V and T_A = 25°C.

NOTE 5: C_{pd} is used to estimate the switching losses according to P_D = C_{pd} × V_{CC}² × f, where f is the switching frequency.



AM26C31

QUADRUPLE DIFFERENTIAL LINE DRIVER

SLLS103J – DECEMBER 1990 – REVISED NOVEMBER 2003

electrical characteristics over recommended ranges of supply voltage and operating free-air temperature (unless otherwise noted)

PARAMETER	TEST CONDITIONS	AM26C31Q AM26C31M			UNIT
		MIN	TYP†	MAX	
V _{OH} High-level output voltage	I _O = -20 mA	2.2	3.4		V
V _{OL} Low-level output voltage	I _O = 20 mA		0.2	0.4	V
V _{OD} Differential output voltage magnitude	R _L = 100 Ω, See Figure 1	2	3.1		V
Δ V _{OD} Change in magnitude of differential output voltage‡	R _L = 100 Ω, See Figure 1			±0.4	V
V _{OC} Common-mode output voltage	R _L = 100 Ω, See Figure 1			3	V
Δ V _{OC} Change in magnitude of common-mode output voltage‡	R _L = 100 Ω, See Figure 1			±0.4	V
I _I Input current	V _I = V _{CC} or GND			±1	μA
I _{O(off)} Driver output current with power off	V _{CC} = 0	V _O = 6 V		100	μA
		V _O = -0.25 V		-100	
I _{OS} Driver output short-circuit current	V _O = 0			-170	mA
I _{OZ} High-impedance off-state output current	V _O = 2.5 V			20	μA
	V _O = 0.5 V			-20	
I _{CC} Quiescent supply current	I _O = 0	V _I = 0 V or 5 V		100	μA
	I _O = 0	V _I = 2.4 V or 0.5 V, See Note 4		3.2	
C _i Input capacitance				6	pF

† All typical values are at V_{CC} = 5 V and T_A = 25°C.

‡ Δ|V_{OD}| and Δ|V_{OC}| are the changes in magnitude of V_{OD} and V_{OC}, respectively, that occur when the input is changed from a high level to a low level.

NOTE 4: This parameter is measured per input. All other inputs are at 0 V or 5 V.

switching characteristics over recommended ranges of supply voltage and operating free-air temperature (unless otherwise noted)

PARAMETER	TEST CONDITIONS	AM26C31Q AM26C31M			UNIT
		MIN	TYP†	MAX	
t _{PLH} Propagation delay time, low- to high-level output	S1 is open, See Figure 2		7	12	ns
t _{PHL} Propagation delay time, high- to low-level output	S1 is open, See Figure 2		6.5	12	ns
t _{sk(p)} Pulse skew time (t _{PLH} - t _{PHL})	S1 is open, See Figure 2		0.5	4	ns
t _{r(OD)} , t _{f(OD)} Differential output rise and fall times	S1 is open, See Figure 3		5	12	ns
t _{PZH} Output enable time to high level	S1 is closed, See Figure 4		10	19	ns
t _{PZL} Output enable time to low level	S1 is closed, See Figure 4		10	19	ns
t _{PHZ} Output disable time from high level	S1 is closed, See Figure 4		7	16	ns
t _{PLZ} Output disable time from low level	S1 is closed, See Figure 4		7	16	ns
C _{pd} Power dissipation capacitance (each driver) (see Note 5)	S1 is open, See Figure 2		100		pF

† All typical values are at V_{CC} = 5 V and T_A = 25°C.

NOTE 5: C_{pd} is used to estimate the switching losses according to P_D = C_{pd} × V_{CC}² × f, where f is the switching frequency.



PARAMETER MEASUREMENT INFORMATION

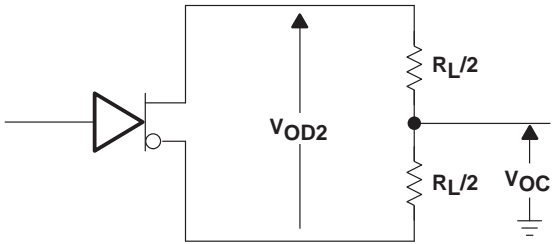
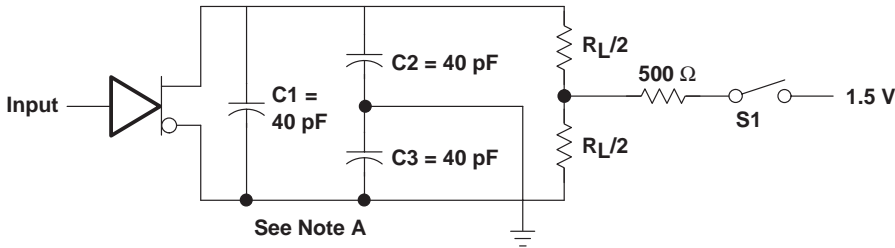
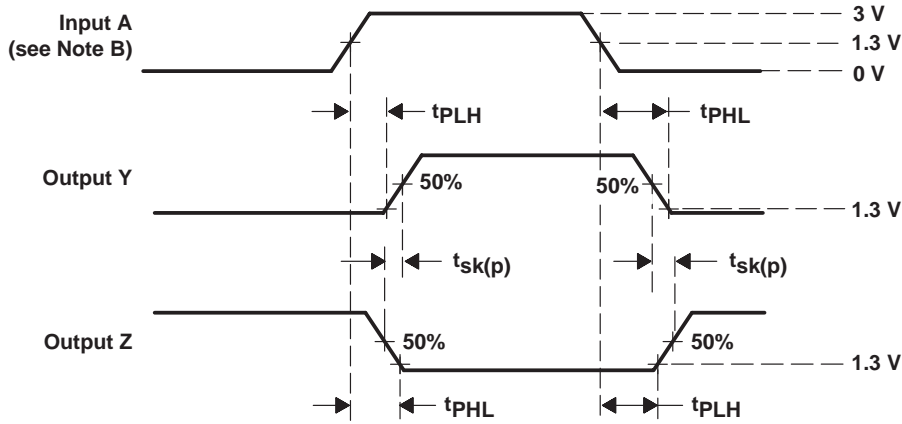

Figure 1. Differential and Common-Mode Output Voltages



TEST CIRCUIT



- NOTES: A. C1, C2, and C3 include probe and jig capacitance.
 B. All input pulses are supplied by generators having the following characteristics: PRR ≤ 1 MHz, duty cycle ≤ 50%, and $t_r, t_f \leq 6$ ns.

Figure 2. Propagation Delay Time and Skew Waveforms and Test Circuit

AM26C31 QUADRUPLE DIFFERENTIAL LINE DRIVER

SLLS103J – DECEMBER 1990 – REVISED NOVEMBER 2003

PARAMETER MEASUREMENT INFORMATION

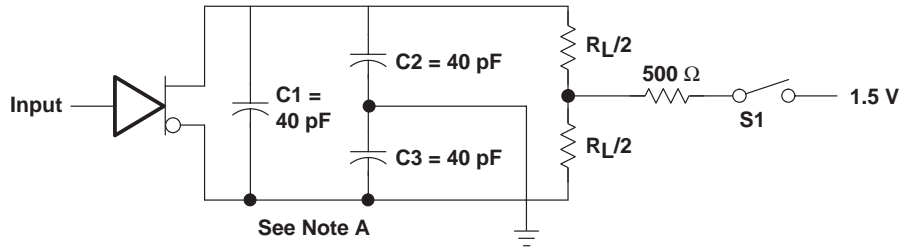

TEST CIRCUIT

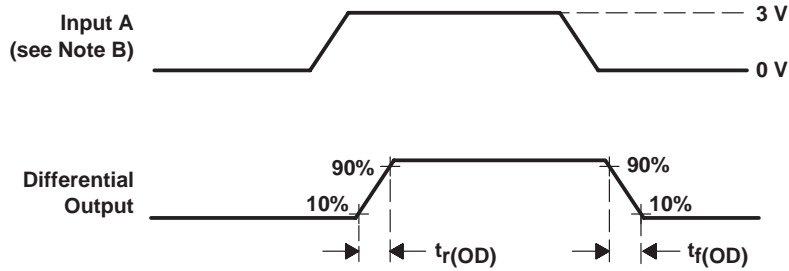

VOLTAGE WAVEFORMS

- NOTES: A. C1, C2, and C3 include probe and jig capacitance.
 B. All input pulses are supplied by generators having the following characteristics: PRR \leq 1 MHz, duty cycle \leq 50%, and $t_r, t_f \leq$ 6 ns.

Figure 3. Differential-Output Rise- and Fall-Time Waveforms and Test Circuit

PARAMETER MEASUREMENT INFORMATION

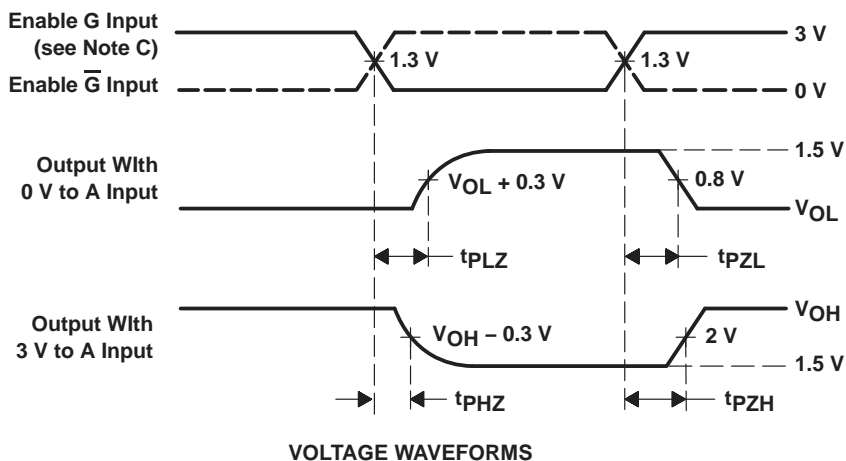
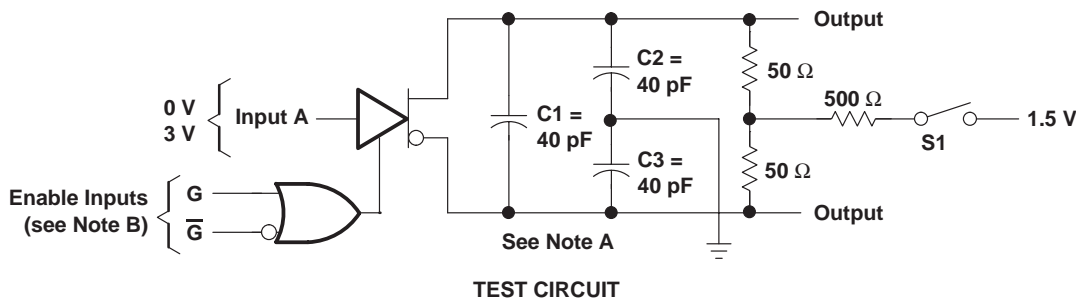

- NOTES: A. C1, C2, and C3 includes probe and jig capacitance.
 B. All input pulses are supplied by generators having the following characteristics: PRR \leq 1 MHz, duty cycle \leq 50%, $t_r < 6$ ns, and $t_f < 6$ ns.
 C. Each enable is tested separately.

Figure 4. Output Enable- and Disable-Time Waveforms and Test Circuit

AM26C31 QUADRUPLE DIFFERENTIAL LINE DRIVER

SLLS103J – DECEMBER 1990 – REVISED NOVEMBER 2003

TYPICAL CHARACTERISTICS

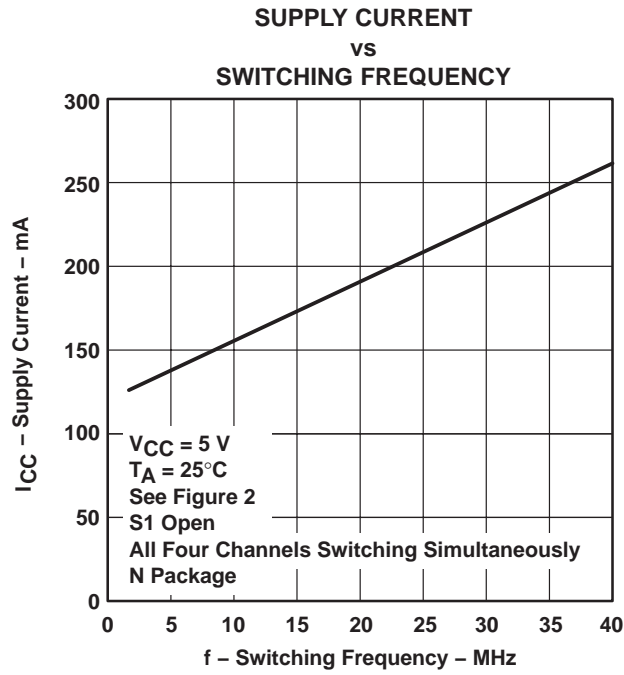

Figure 5

J (R-GDIP-T**)

14 LEADS SHOWN

CERAMIC DUAL IN-LINE PACKAGE



DIM \ PINS **	14	16	18	20
A	0.300 (7,62) BSC	0.300 (7,62) BSC	0.300 (7,62) BSC	0.300 (7,62) BSC
B MAX	0.785 (19,94)	.840 (21,34)	0.960 (24,38)	1.060 (26,92)
B MIN	—	—	—	—
C MAX	0.300 (7,62)	0.300 (7,62)	0.310 (7,87)	0.300 (7,62)
C MIN	0.245 (6,22)	0.245 (6,22)	0.220 (5,59)	0.245 (6,22)



4040083/F 03/03

- NOTES:
- All linear dimensions are in inches (millimeters).
 - This drawing is subject to change without notice.
 - This package is hermetically sealed with a ceramic lid using glass frit.
 - Index point is provided on cap for terminal identification only on press ceramic glass frit seal only.
 - Falls within MIL STD 1835 GDIP1-T14, GDIP1-T16, GDIP1-T18 and GDIP1-T20.

W (R-GDFP-F16)

CERAMIC DUAL FLATPACK

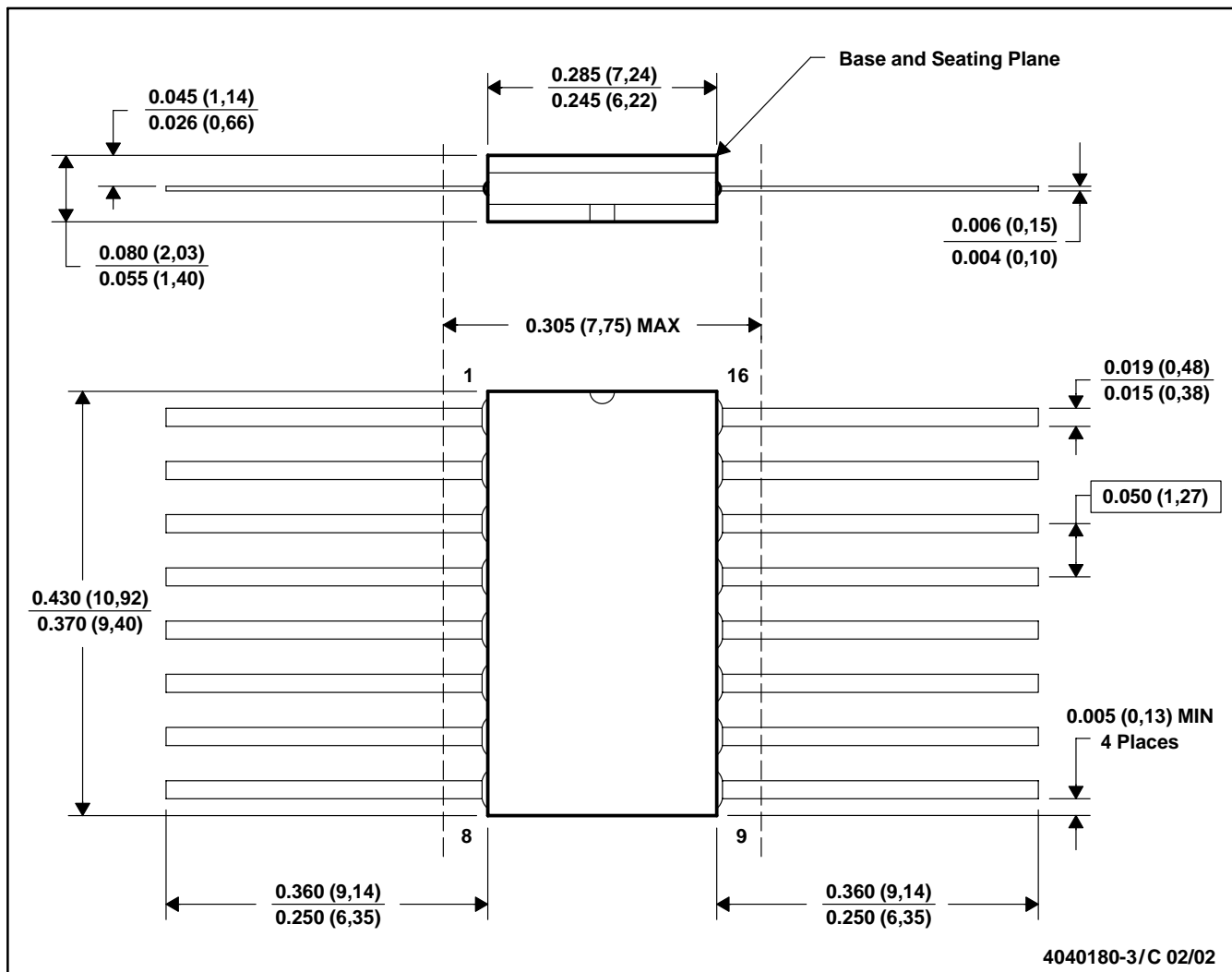

- NOTES: A. All linear dimensions are in inches (millimeters).
 B. This drawing is subject to change without notice.
 C. This package can be hermetically sealed with a ceramic lid using glass frit.
 D. Index point is provided on cap for terminal identification only.
 E. Falls within MIL STD 1835 GDFP-1F16 and JEDEC MO-092AC

FK (S-CQCC-N**)

LEADLESS CERAMIC CHIP CARRIER

28 TERMINAL SHOWN



- NOTES:
- A. All linear dimensions are in inches (millimeters).
 - B. This drawing is subject to change without notice.
 - C. This package can be hermetically sealed with a metal lid.
 - D. The terminals are gold plated.
 - E. Falls within JEDEC MS-004

N (R-PDIP-T**)

PLASTIC DUAL-IN-LINE PACKAGE

16 PINS SHOWN

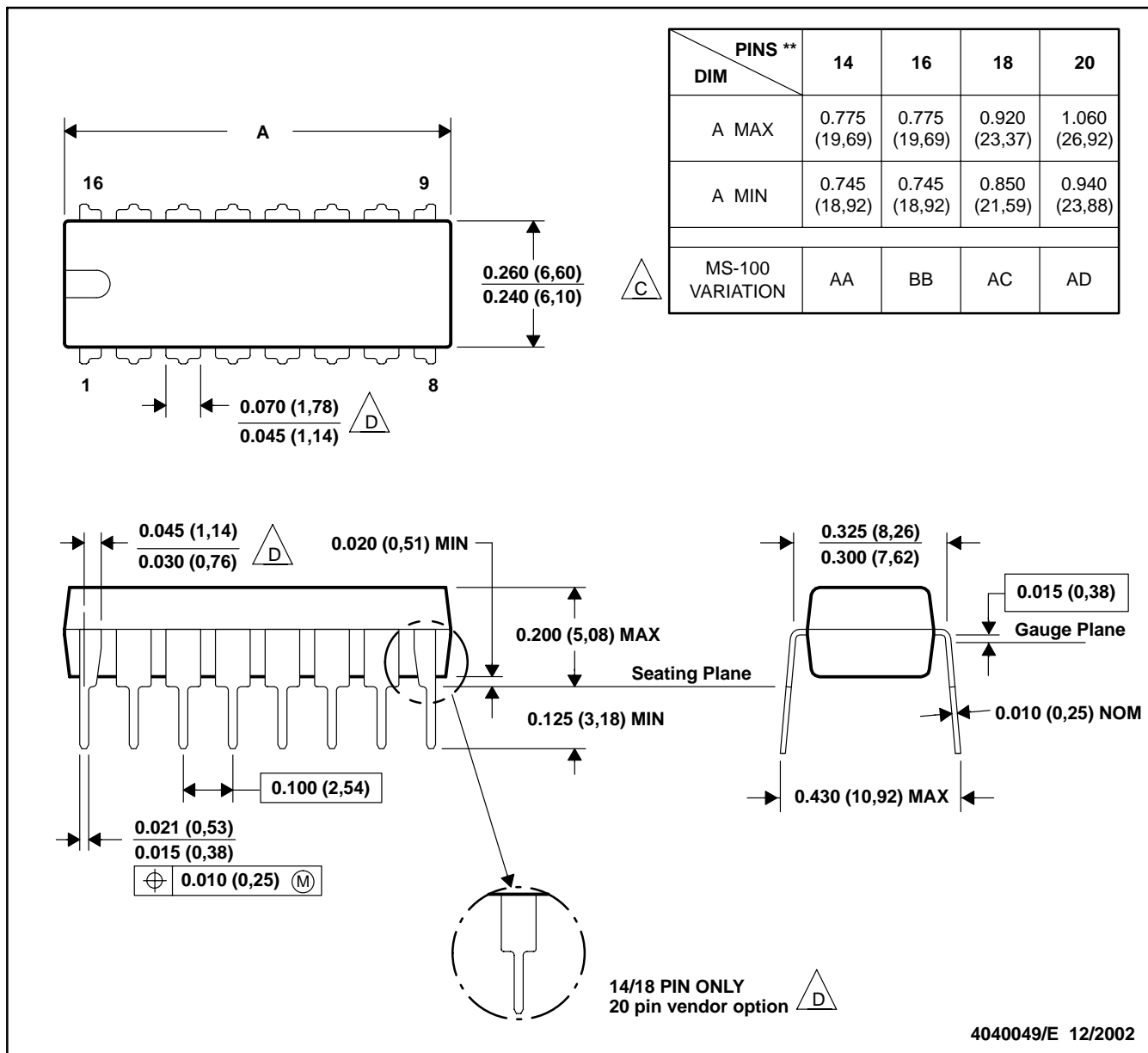

- NOTES: A. All linear dimensions are in inches (millimeters).
 B. This drawing is subject to change without notice.
 C. Falls within JEDEC MS-001, except 18 and 20 pin minimum body length (Dim A).
 D. The 20 pin end lead shoulder width is a vendor option, either half or full width.

4040049/E 12/2002

D (R-PDSO-G**)

PLASTIC SMALL-OUTLINE PACKAGE

8 PINS SHOWN



- NOTES: A. All linear dimensions are in inches (millimeters).
 B. This drawing is subject to change without notice.
 C. Body dimensions do not include mold flash or protrusion, not to exceed 0.006 (0,15).
 D. Falls within JEDEC MS-012

MECHANICAL DATA

NS (R-PDSO-G**)

PLASTIC SMALL-OUTLINE PACKAGE

14-PINS SHOWN



- NOTES:
- A. All linear dimensions are in millimeters.
 - B. This drawing is subject to change without notice.
 - C. Body dimensions do not include mold flash or protrusion, not to exceed 0,15.

DB (R-PDSO-G**)

PLASTIC SMALL-OUTLINE

28 PINS SHOWN



- NOTES: A. All linear dimensions are in millimeters.
 B. This drawing is subject to change without notice.
 C. Body dimensions do not include mold flash or protrusion not to exceed 0,15.
 D. Falls within JEDEC MO-150

IMPORTANT NOTICE

Texas Instruments Incorporated and its subsidiaries (TI) reserve the right to make corrections, modifications, enhancements, improvements, and other changes to its products and services at any time and to discontinue any product or service without notice. Customers should obtain the latest relevant information before placing orders and should verify that such information is current and complete. All products are sold subject to TI's terms and conditions of sale supplied at the time of order acknowledgment.

TI warrants performance of its hardware products to the specifications applicable at the time of sale in accordance with TI's standard warranty. Testing and other quality control techniques are used to the extent TI deems necessary to support this warranty. Except where mandated by government requirements, testing of all parameters of each product is not necessarily performed.

TI assumes no liability for applications assistance or customer product design. Customers are responsible for their products and applications using TI components. To minimize the risks associated with customer products and applications, customers should provide adequate design and operating safeguards.

TI does not warrant or represent that any license, either express or implied, is granted under any TI patent right, copyright, mask work right, or other TI intellectual property right relating to any combination, machine, or process in which TI products or services are used. Information published by TI regarding third-party products or services does not constitute a license from TI to use such products or services or a warranty or endorsement thereof. Use of such information may require a license from a third party under the patents or other intellectual property of the third party, or a license from TI under the patents or other intellectual property of TI.

Reproduction of information in TI data books or data sheets is permissible only if reproduction is without alteration and is accompanied by all associated warranties, conditions, limitations, and notices. Reproduction of this information with alteration is an unfair and deceptive business practice. TI is not responsible or liable for such altered documentation.

Resale of TI products or services with statements different from or beyond the parameters stated by TI for that product or service voids all express and any implied warranties for the associated TI product or service and is an unfair and deceptive business practice. TI is not responsible or liable for any such statements.

Following are URLs where you can obtain information on other Texas Instruments products and application solutions:

Products		Applications	
Amplifiers	amplifier.ti.com	Audio	www.ti.com/audio
Data Converters	dataconverter.ti.com	Automotive	www.ti.com/automotive
DSP	dsp.ti.com	Broadband	www.ti.com/broadband
Interface	interface.ti.com	Digital Control	www.ti.com/digitalcontrol
Logic	logic.ti.com	Military	www.ti.com/military
Power Mgmt	power.ti.com	Optical Networking	www.ti.com/opticalnetwork
Microcontrollers	microcontroller.ti.com	Security	www.ti.com/security
		Telephony	www.ti.com/telephony
		Video & Imaging	www.ti.com/video
		Wireless	www.ti.com/wireless

Mailing Address: Texas Instruments
Post Office Box 655303 Dallas, Texas 75265

Copyright © 2003, Texas Instruments Incorporated