

# LUMILEDS™

## Technical Data Super Flux LEDs

### Features

- High flux output
- Designed for high current operation
- Low thermal resistance
- Low profile
- Meets SAE/ECE/JIS automotive color requirements
- Packaged in tubes for use with automatic insertion equipment

### Benefits

- Fewer LEDs required
- Lowers lighting system cost

### Applications

- Automotive exterior lighting
- Electronic signs and signals

HPWA-MH00	HPWT-MH00
HPWA-DH00	HPWT-DH00
HPWT-RD00	HPWT-BH00
HPWT-MD00	HPWT-RL00
HPWT-DD00	HPWT-ML00
HPWT-BD00	HPWT-DL00
HPWT-RH00	HPWT-BL00

This revolutionary package design allows the lighting designer to reduce the number of LEDs required and provide a more uniform and unique illuminated appearance than with other LED solutions. This is possible through the efficient optical package design and high-current capabilities.

The low profile package can be easily coupled with reflectors or lenses to efficiently distribute light and provide the desired lit appearance.

This product family employs the world's brightest red-orange and amber LED materials, which allow designers to match the color of popular lighting applications, such as automotive tail, stop and turn signal lamps, and electronic signs.

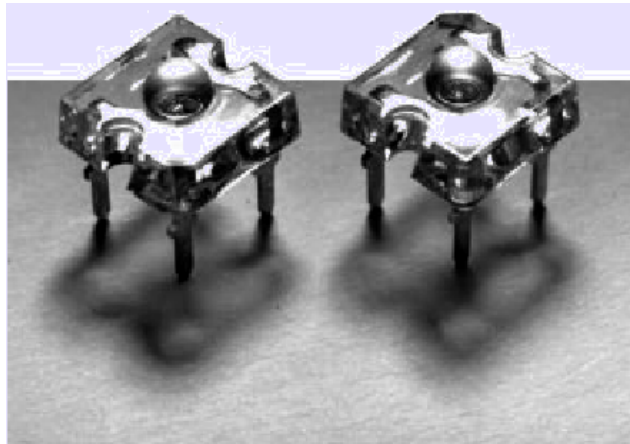

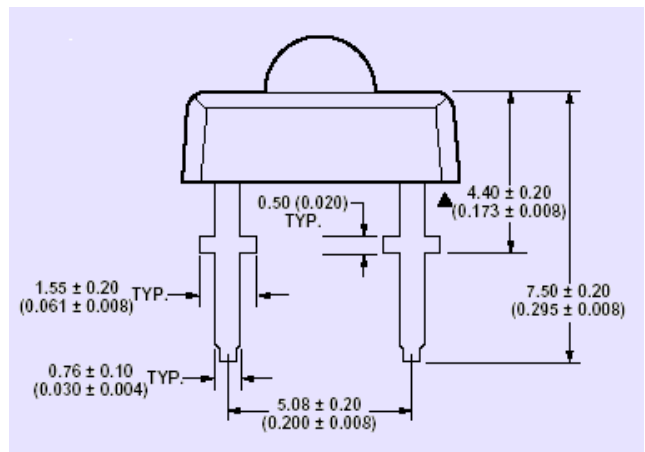
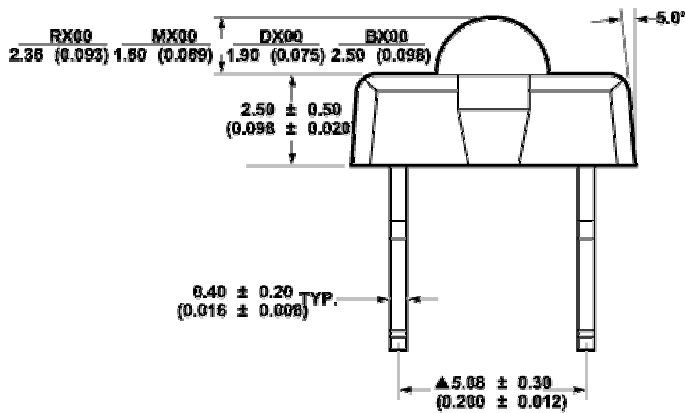
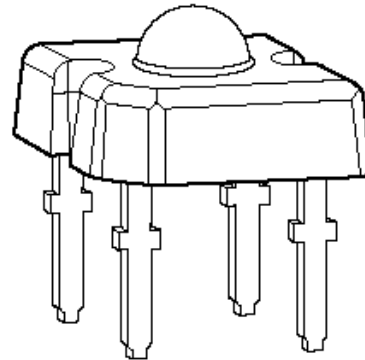
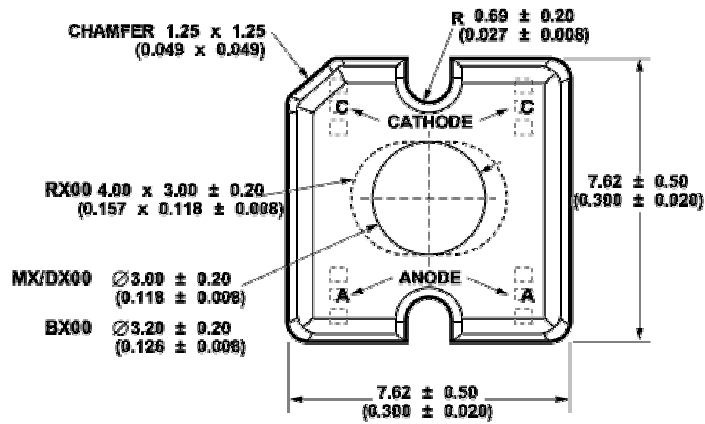

- NOTES:
1. DIMENSIONS ARE IN MILLIMETERS (INCHES).
  2. DIMENSIONS WITHOUT TOLERANCES ARE NOMINAL.
  3. CATHODE LEADS ARE INDICATED WITH A "C" AND ANODE LEADS ARE INDICATED WITH AN "A".
  4. ▲ DENOTES SPECIAL CHARACTERISTIC.

## Device Selection Guide

Part Number	LED Color	Total Flux $\theta_v$ (mIm) @ 70 mA <sup>[1]</sup> Typ.	Total Included Angle $\theta_{90V}$ (Degrees) <sup>[2]</sup> Typ.
HPWA-MH00-00000	AS AlInGaP Red-Orange	1500	95
HPWA-DH00-00000			75
HPWT-RD00-00000			44 x 88
HPWT-MD00-00000	TS AlInGaP Red	3000	100
HPWT-DD00-00000			70
HPWT-BD00-00000			50
HPWT-RH00-00000			44 x 88
HPWT-MH00-00000	TS AlInGaP Red-Orange	3750	100
HPWT-DH00-00000			70
HPWT-BH00-00000			50
HPWT-RL00-00000	TS AlInGaP Amber	1500	44 x 88
HPWT-ML00-00000			100
HPWT-DL00-00000			70
HPWT-BL00-00000			50

Notes:

- $\theta_v$  is the total luminous flux output as measured with an integrating sphere after the device has stabilized ( $R\theta_{j-a} = 200^\circ$  C/W,  $T_A = 25^\circ$  C).
- $\theta_{0.90V}$  is the included angle at which 90% of the total luminous flux is captured.

## Absolute Maximum Ratings at $T_A = 25^\circ$

Parameter	HPWA-XX00	HPWT-XX00	Units
DC Forward Current [1, 2]	70	70	mA
Power Dissipation	187	221	mW
Reverse Voltage ( $I_R = 100 \mu$ A)	10	10	V
Operating Temperature Range	-40 to +100	-40 to +100	$^\circ$ C
Storage Temperature	-55 to +100	-55 to +100	$^\circ$ C
High Temperature Chamber	125 $^\circ$ C, 2 Hours		
LED Junction Temperature	125 $^\circ$ C		
Solder Conditions			
Preheat Temperature	100 $^\circ$ C for 30 seconds		
Solder Temperature	260 $^\circ$ C for 5 seconds		
	[1.5 mm (0.06 in.) below seating plane]		

Notes:

- Derate linearly as shown in Figures 4a and 4b.
- Operation at currents below 10 mA is not recommended, please contact your sales representative or Future Electronics.

## Optical Characteristics at $T_A = 25^\circ\text{C}$ , $I_F = 70\text{ mA}$ , $R_{\theta J-A} = 200^\circ\text{C C/W}$

Device Type	Total Flux $\theta$ (mim) <sup>[1]</sup>		Peak Wavelength $\lambda$ peak (nm)	Color, Dominant Wavelength $\lambda$ peak (nm) <sup>[2]</sup>	Total Included Angle $\theta_{0.90V}$ (Degrees) <sup>[3]</sup>	Luminous Intensity/ Total Flux $I_V$ (mcd)/ $\Phi_V$ (mim)	Viewing Angle $2\theta$ 1/2 (Degrees)
	Min.	Typ.	Typ.	Typ.	Typ.	Typ.	Typ.
HPWA-MH00	600	1500	624	618	95	0.6	90
HPWA-DH00					75	0.9	60
HPWT-RD00	1000	3000	640	630	44 x 88	1.25	25 x 68
HPWT-MD00					100	0.6	70
HPWT-DD00					70	1.5	40
HPWT-BD00					50	2.0	30
HPWT-RH00					44 x 88	1.25	25 x 68
HPWT-MH00					100	0.6	70
HPWT-DH00	1000	3750	626	620	70	1.5	40
HPWT-BH00					50	2.0	30
HPWT-RL00	1000	1500	596	594	44 x 88	1.25	25 x 68
HPWT-ML00					100	0.6	70
HPWT-DL00					70	1.5	40
HPWT-BL00					50	2.0	30

### Notes:

- $\Phi_V$  is the total luminous flux output as measured with an integrating sphere after the device has stabilized.
- The dominant wavelength is derived from the CIE Chromaticity Diagram and represents the perceived color of the device.
- $\theta_{0.90V}$  is the included angle at which 90% of the total luminous flux is captured.

## Electrical Characteristics at $T_A = 25^\circ\text{C}$

Device Type	Forward Voltage $V_F$ (Volts) @ $I_F = 70\text{ mA}$			Reverse Breakdown $V_R$ (Volts) @ $I_R = 100\ \mu\text{A}$		Capacitance C (pF) $V_F = 0$ , $f = 1\text{MHz}$	Thermal Resistance $R_{\theta J-PIN}$ ( $^\circ\text{C/W}$ )	Speed of Response $\tau_s$ (ns) <sup>[1]</sup>
	Min.	Typ.	Max.	Min.	Typ.	Typ.	Typ.	Typ.
HPWA-XH00	1.83	2.1	2.67	10	20	40	155	20
HPWT-XD00	2.15	2.5	3.03	10	20	40	155	20
HPWT-XH00	2.15	2.5	3.03	10	20	40	155	20
HPWT-XL00	2.15	2.6	3.15	10	20	40	155	20

### Note:

$\tau_s$  is the time constant,  $e^{-t/\tau_s}$ .

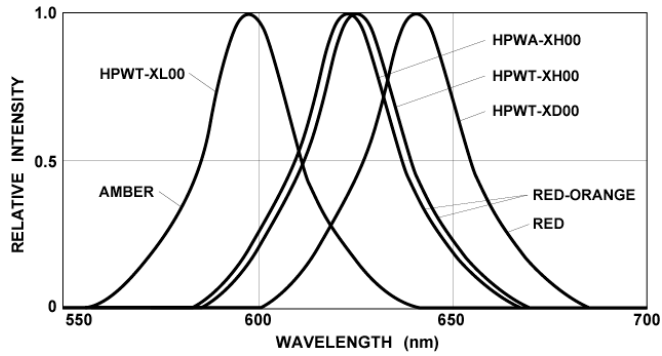

Figure 1. Relative Intensity vs. Wavelength

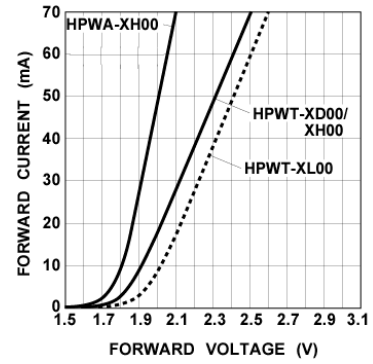

Figure 2. Forward Current vs. Forward Voltage.

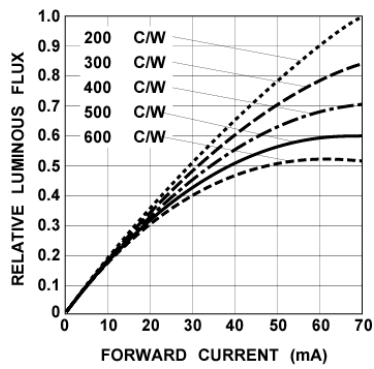

Figure 3. HPWA/HPWT-XX00 Relative Luminous Flux vs. Forward Current.

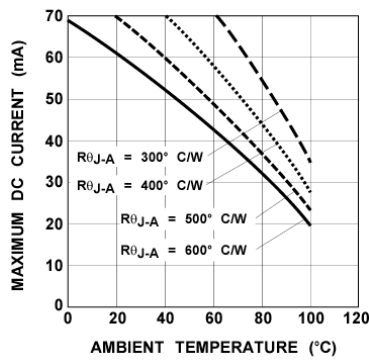

Figure 4a. HPWA-XX00 Maximum DC Forward Current vs. Ambient Temperature.

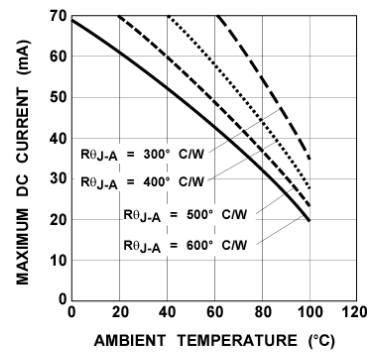

Figure 4b. HPWT-XX00 Maximum DC Forward Current vs. Ambient Temperature.

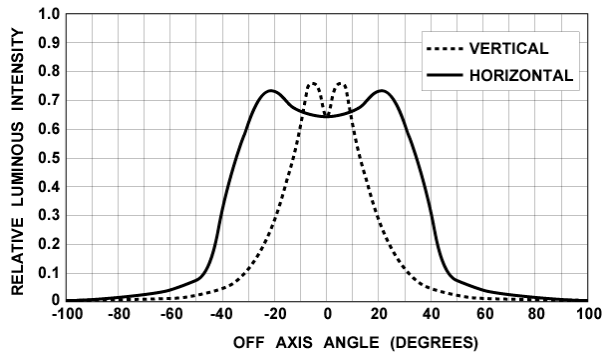

Figure 5a. HPWT-RX00 Relative Luminous Intensity vs. Off Axis Angle.

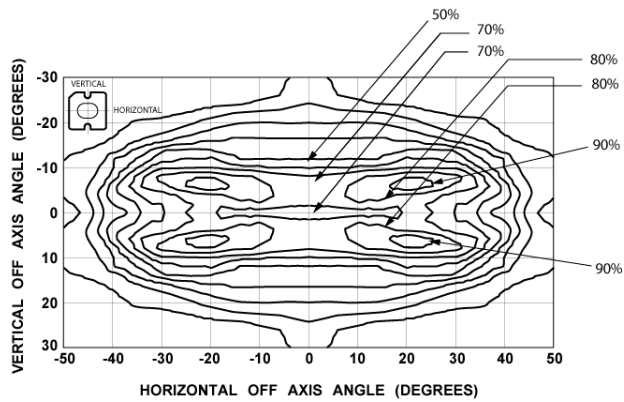

Figure 5b. HPWT-RX00 Relative Luminous Intensity vs. Off Axis Angle. Iso-Intensity Contour Plot.

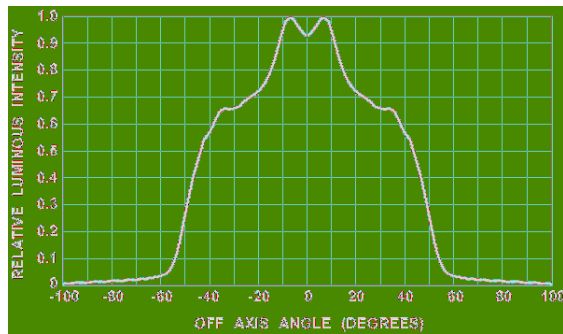

Figure 5c. HPWA-MX00 Relative Luminous Intensity vs. Off Axis Angle.

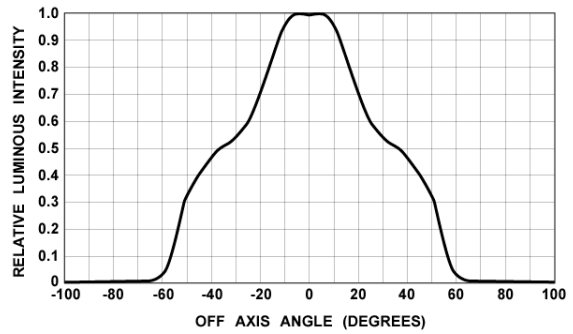

Figure 5d. HPWT-MX00 Relative Luminous Intensity vs. Off Axis Angle.

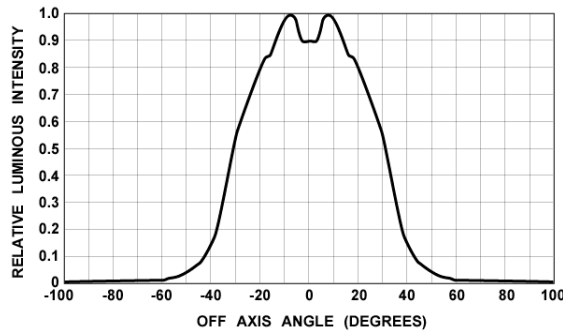

Figure 5e. HPWA-DX00 Relative Luminous Intensity vs. Off Axis Angle.

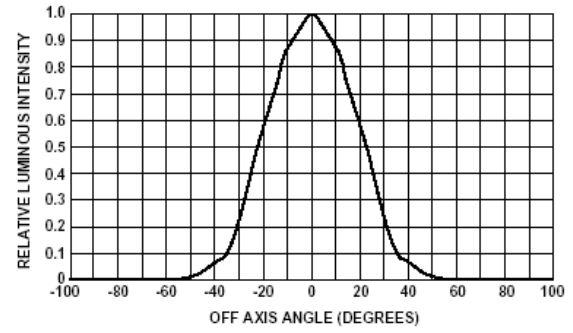

Figure 5f. HPWT-DX00 Relative Luminous Intensity vs. Off Axis Angle.

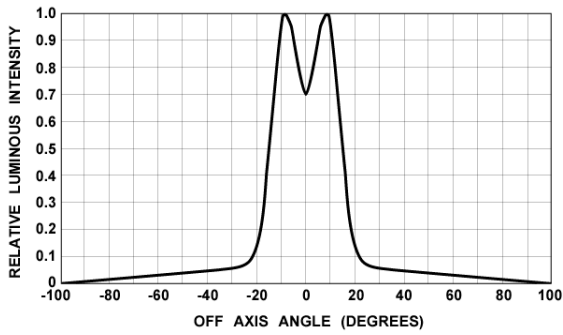

Figure 5g. HPWA-BX00 Relative Luminous Intensity vs. Off Axis Angle.

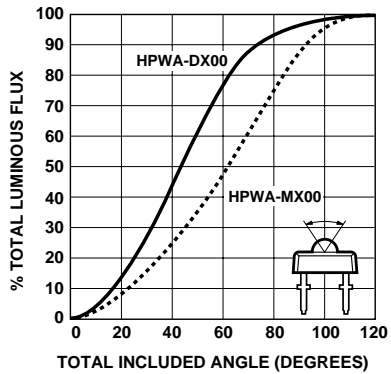

Figure 6a. HPWA-XX00 Percent Total Luminous Flux vs. Total Included Angle.

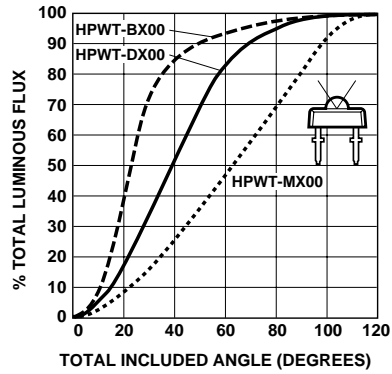

Figure 6b. HPWT-XX00 Percent Total Luminous Flux vs. Total Included Angle.

For additional information about Super Flux LEDs, please refer to Lumileds Application Note 1149. Copies of the application brief can be obtained from your local field sales engineer. You may also visit the Lumileds web site at [www.lumileds.com](http://www.lumileds.com).

# LUMILEDS

LIGHT FROM SILICON VALLEY

Lumileds is a world-class supplier of Light Emitting Diodes (LEDs) producing billions of LEDs annually. Lumileds is a fully integrated supplier, producing core LED material in all three base colors (Red, Green, Blue) and White. Lumileds has R&D development centers in San Jose, California and Best, The Netherlands. Production capabilities in San Jose, California and Malaysia.

Lumileds is pioneering the high-flux LED technology and bridging the gap between solid state LED technology and the lighting world. Lumileds is absolutely dedicated to bringing the best and brightest LED technology to enable new applications and markets in the Lighting world.

**[www.lumileds.com](http://www.lumileds.com)**

For technical assistance or the location of your nearest Lumileds sales office, call:

**Worldwide:**  
408-435-6044  
US Toll free: 877-298-9455  
Fax: 408-435-6855  
Email us at [info@lumileds.com](mailto:info@lumileds.com)

Data subject to change.  
Copyright © 2001  
Lumileds Lighting, LLC  
370 West Trimble Road  
San Jose, CA 95131

Publication No. DS??  
(August 2001)